

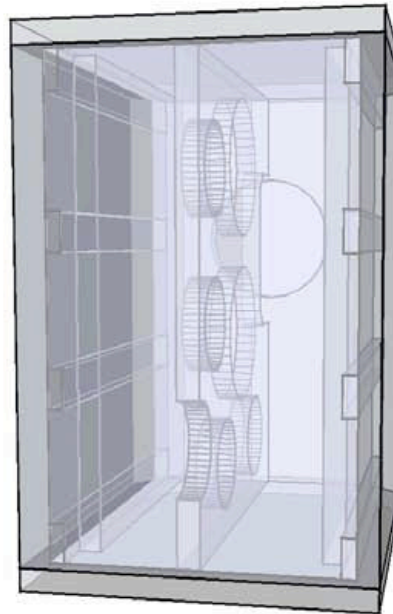

FE127eN Fonken v1.0.3b
Visualization

© 2009 planet_10 enterprises limited
designed & drawn by D Dlugos | 13-nov-09
for non-commercial use only

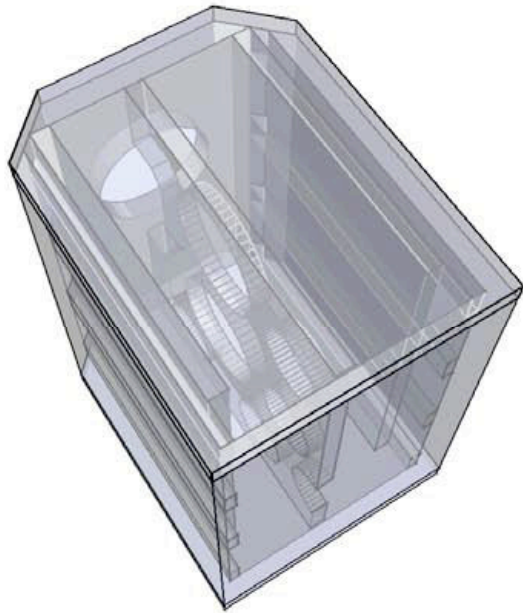

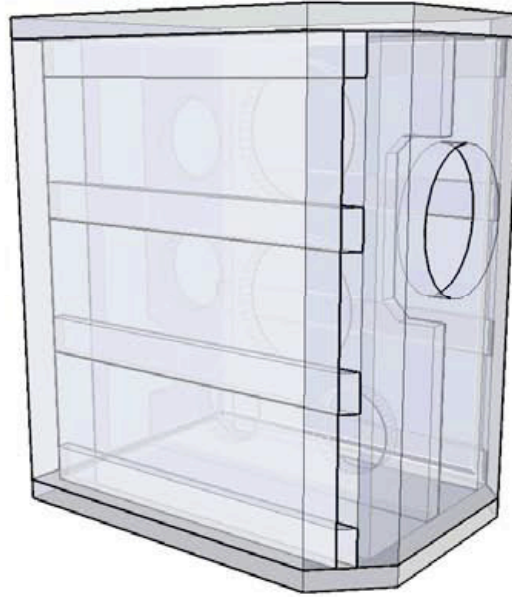
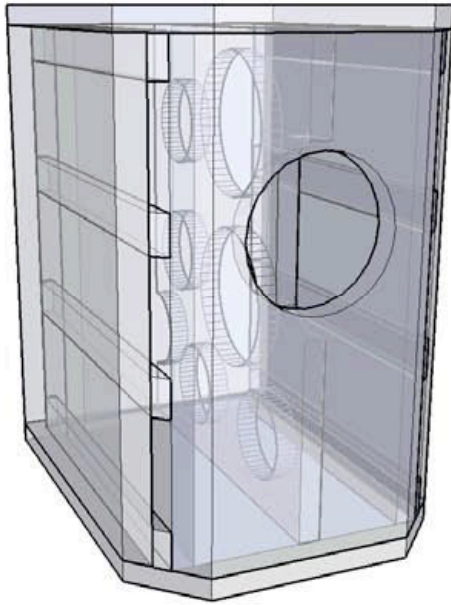

FE127eN Fonken
Some Pictures

© 2009, 2010, 2011 planet_10 enterprises limited
designed & drawn by D Dlugos | 21-mar-11
for non-commercial use only

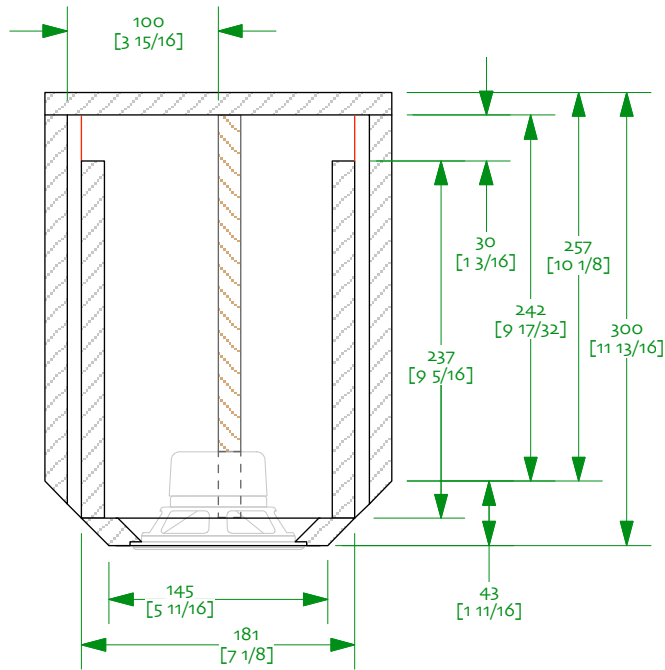

Notes:

0/ Designed for modified Fostex FE127eN, will work well with stock driver

1/ All panels 15mm (5/8") thick baffle is 15 or 18mm (3/4") - 18mm in drawing

2/ Box should be made from Baltic Birch plywood or other void-free, many-ply plywood

3/ Ports are 75mm (2 15/16") long by 9.5mm (3/8") thick - 3 per side with 4 - 1 1/32" (26.4mm) solid spacers (spacers run all the way to the back of the box). MDF or solid wood spacers are preferred

4/ Brace shape is only suggestive - prime purpose is to brace speaker, it needs to be about 35-40% holes. (if you have to mount a terminal cup in the middle, you'll want to make sure the brace allows clearance)

5/ Don't forget to angle cut the back of the driver cut-out to give it breathing room

6/ All internal panels lined with ~1/2" (12mm) wool or cotton felt (preferred), 3/4" (19mm) poly-fluff batting, or 1" (25mm) fiberglass Note that it is hard to get into the box after it is sealed up



FE127eN Fonken v1.0.4
Dimensional Drawing (15/18mm)

© 2007-2013 planet_10 enterprises limited
designed & drawn by D Dlugos | 24-feb-13
for non-commercial use only

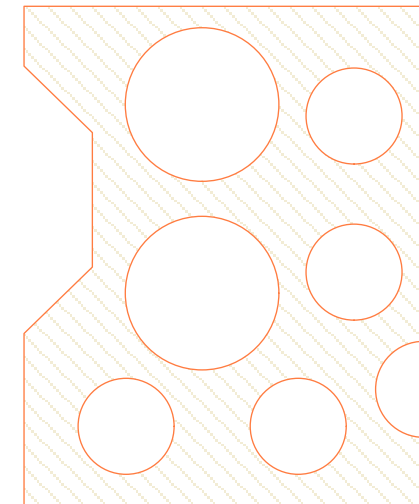
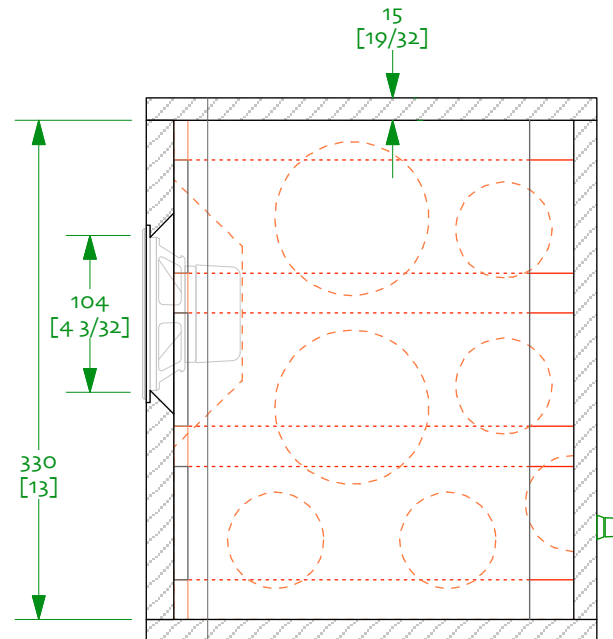
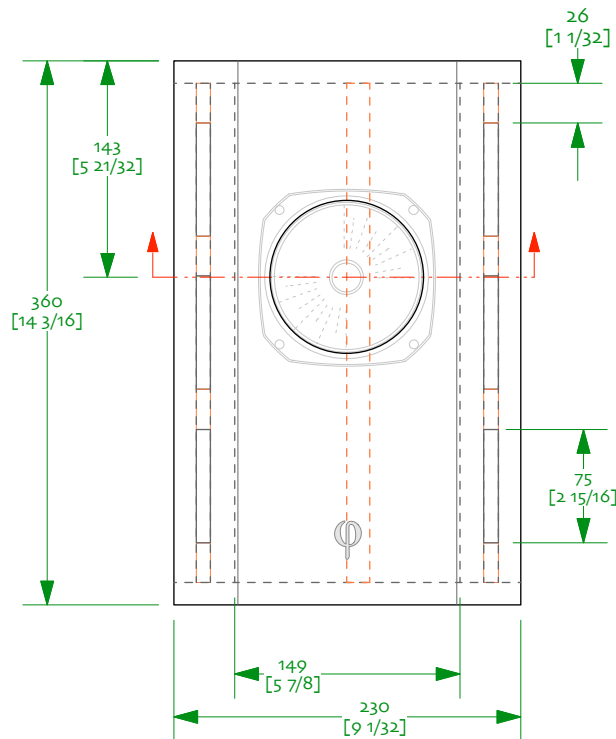

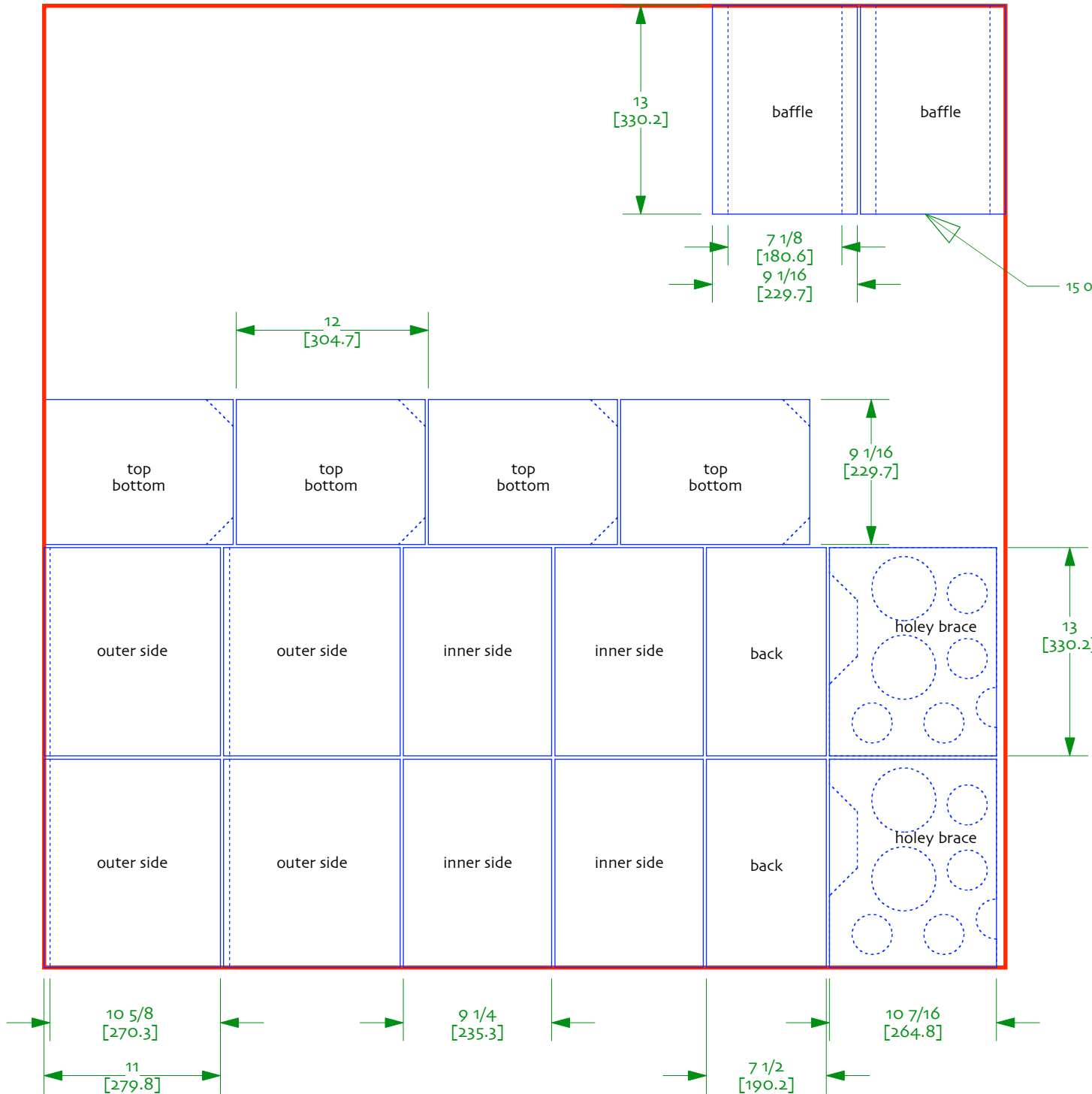

15 or 18 mm (5/8 - 3/4")

9.5 mm (3/8")

port slot
port slot
port slot
port slot
port slot
port slot
port slot
port slot
port slot
port slot
port slot
port slot
port slot
port slot
port slot
port slot
port slot
port slot

Note:
 o/ 15mm material
 1/ dotted line represents where chamfer will shorten panel
 2/ 5mm kerf allowance shown

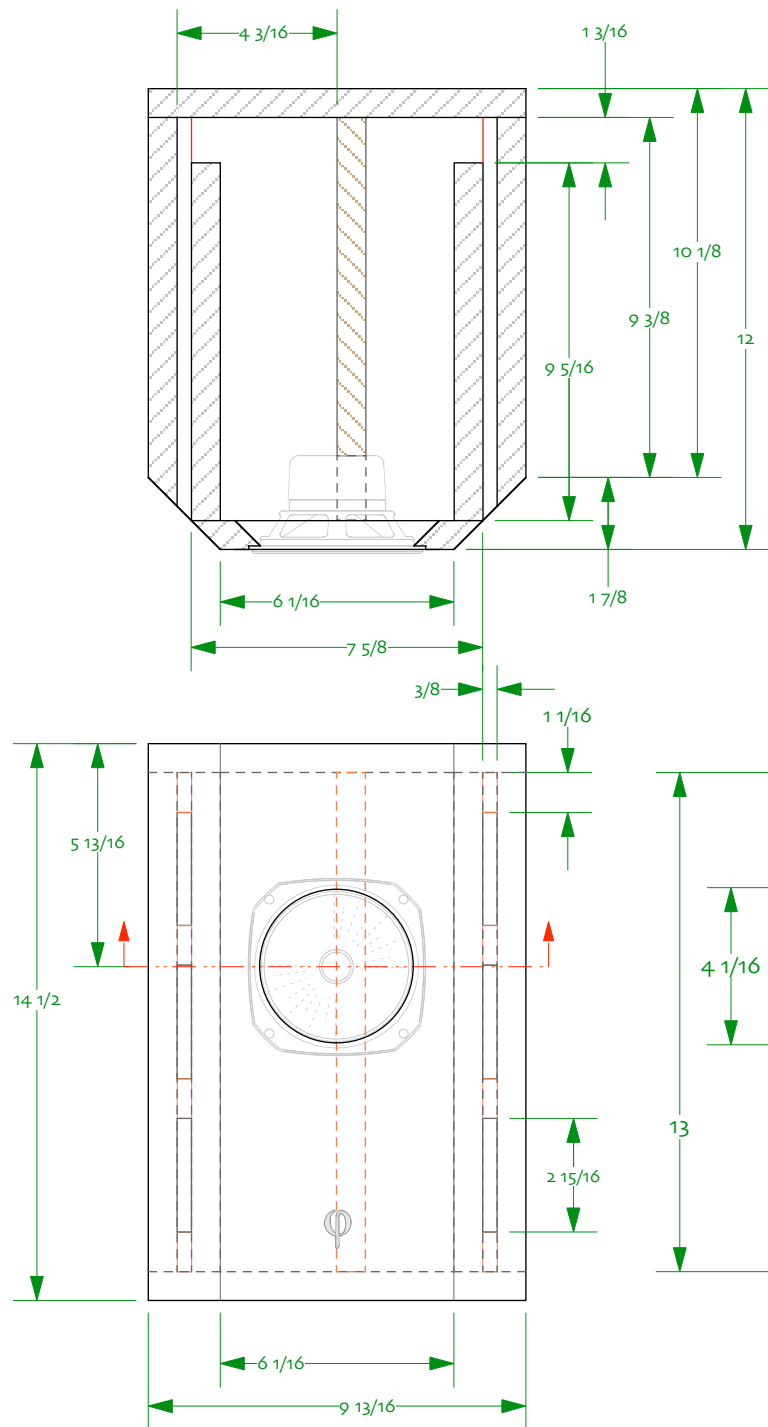

Notes:

- 0/ Designed for modified Fostex FE127eN, will work well with stock driver
- 1/ All panels 3/4" thick
- 2/ Box should be made from Baltic Birch plywood or other void-free, many-ply plywood
- 3/ Ports are 2 15/16" long by 3/8" wide – 3 per side with 4 – 1 1/32" solid spacers (spacers run all the way to the back of the box). MDF or solid wood spacers are preferred
- 4/ Brace shape is only suggestive – prime purpose is to brace speaker, it needs to be about 35-40% holes. (if you have to mount a terminal cup in the middle, you'll want to make sure the brace allows clearance)
- 5/ Don't forget to angle cut the back of the driver cut-out to give it breathing room
- 6/ All internal panels lined with ~1/2" (12mm) wool or cotton felt (preferred), 3/4" (19mm) poly-fluff batting, or 1" (25mm) fiberglass Note that it is hard to get into the box after it is sealed up

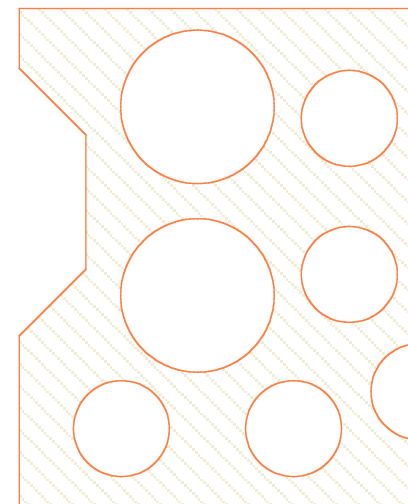
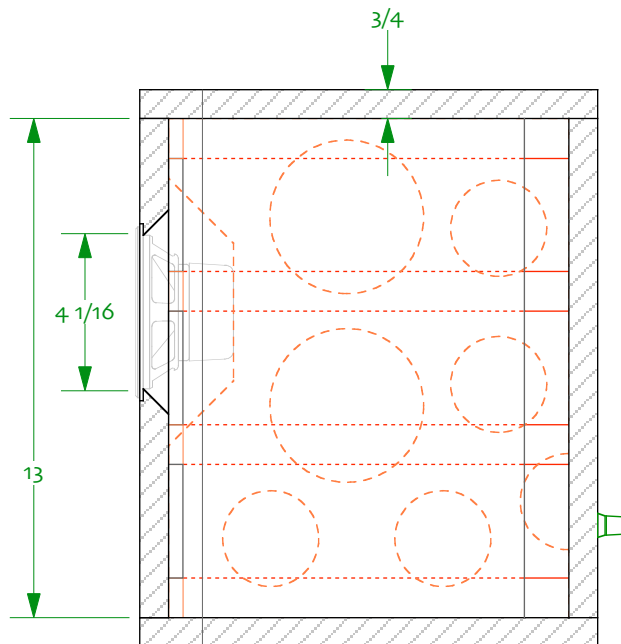

FE127eN Fonken v1.0.3b
Dimensional Drawing (3/4")

© 2007, 2008, 2009 planet_10 enterprises limited
designed & drawn by D Dlugos | 14nov-09
for non-commercial use only

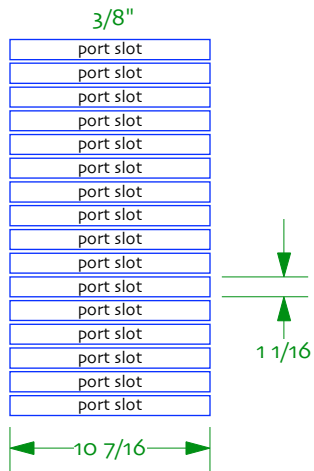

Note:

o/ 3/4" material

1/ dotted line represents where chamfer will shorten panel

2/ 5mm kerf allowance shown



FE127eN Fonken v1.0.4b
4x8 Cut Plan (3/4")

© 2009 planet_10 enterprises limited
designed & drawn by D Dlugos | 14-november-09
for non-commercial use only

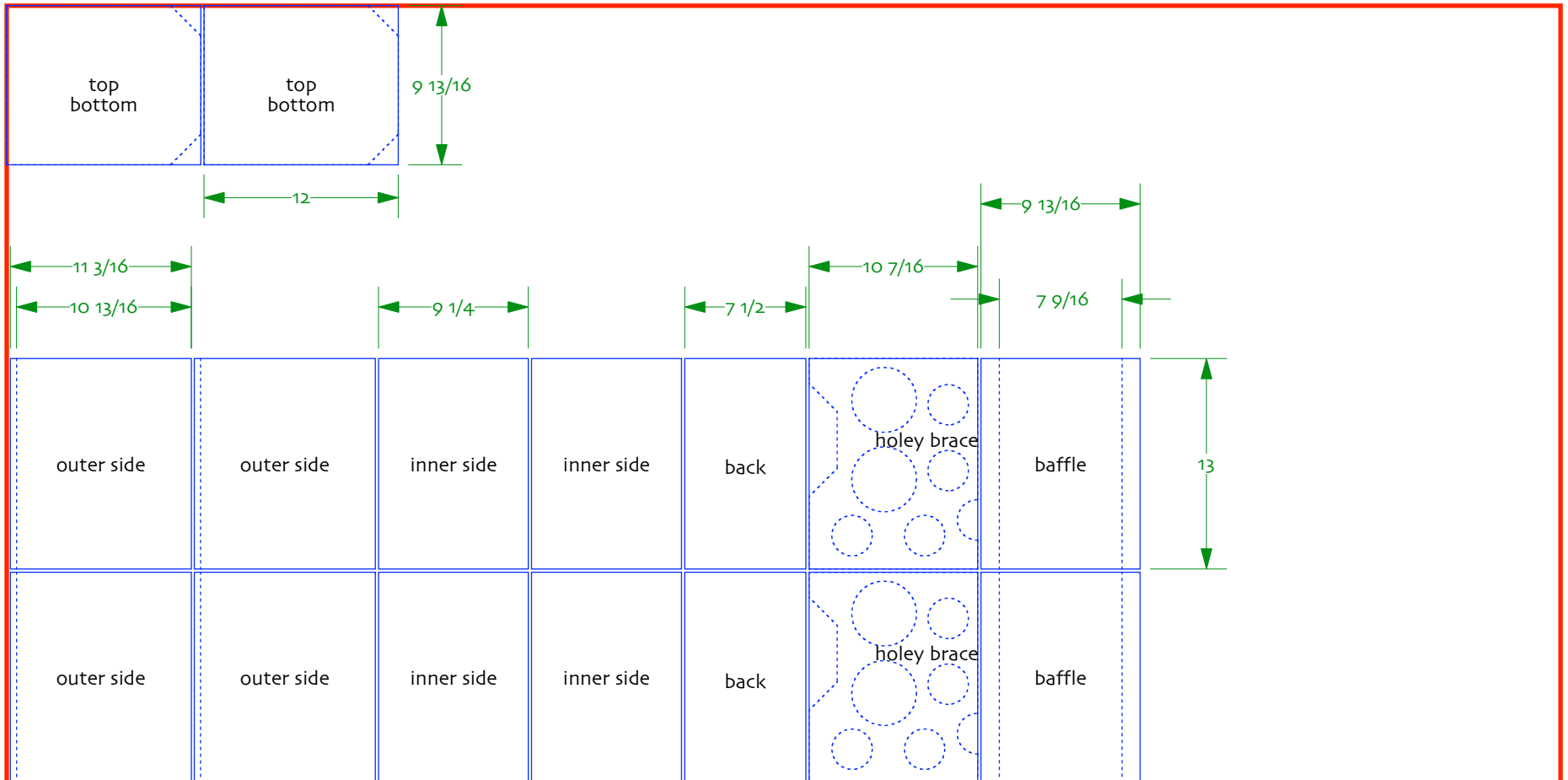

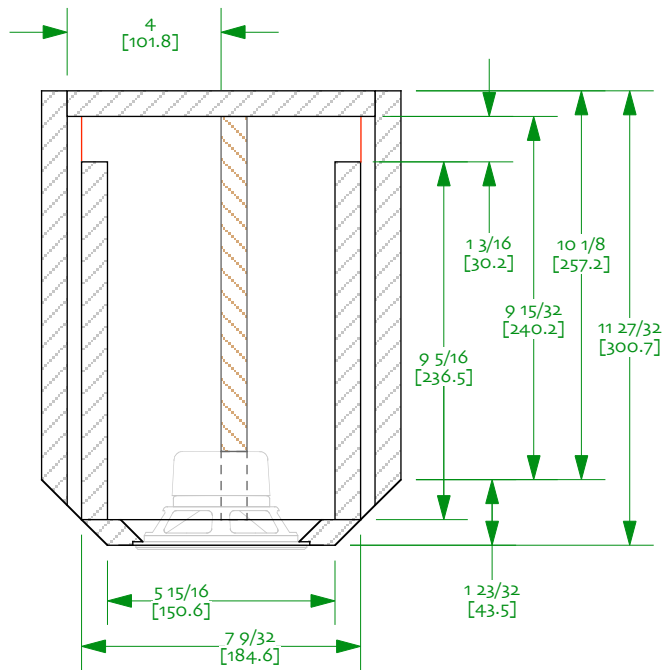

Notes:

0/ Designed for modified Fostex FE127eN, will work well with stock driver

1/ All panels 17mm

2/ Box should be made from Baltic Birch plywood or other void-free, many-ply plywood

3/ Ports are 75mm (2 15/16") long by 9.5mm (3/8") thick - 3 per side with 4 - 1 1/32" (26.4mm) solid spacers (spacers run all the way to the back of the box). MDF or solid wood spacers are preferred

4/ Brace shape is only suggestive - prime purpose is to brace speaker, it needs to be about 35-40% holes. (if you have to mount a terminal cup in the middle, you'll want to make sure the brace allows clearance)

5/ Don't forget to angle cut the back of the driver cut-out to give it breathing room

6/ All internal panels lined with ~1/2" (12mm) wool or cotton felt (preferred), 3/4" (19mm) poly-fluff batting, or 1" (25mm) fiberglass Note that it is hard to get into the box after it is sealed up



FE127eN Fonken v1.0.3b
Dimensional Drawing (17mm)

© 2007, 2008, 2009, 2010 planet_10 enterprises limited
designed & drawn by D Dlugos | 09-apr-10
for non-commercial use only

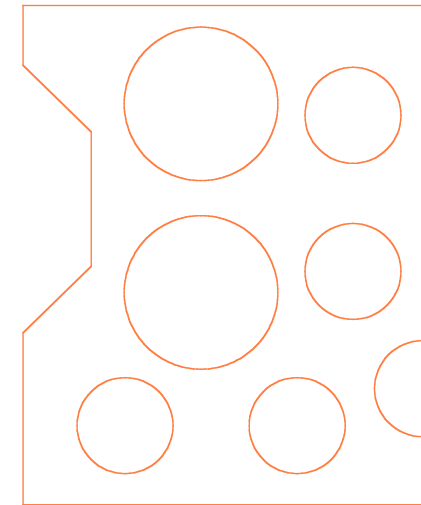
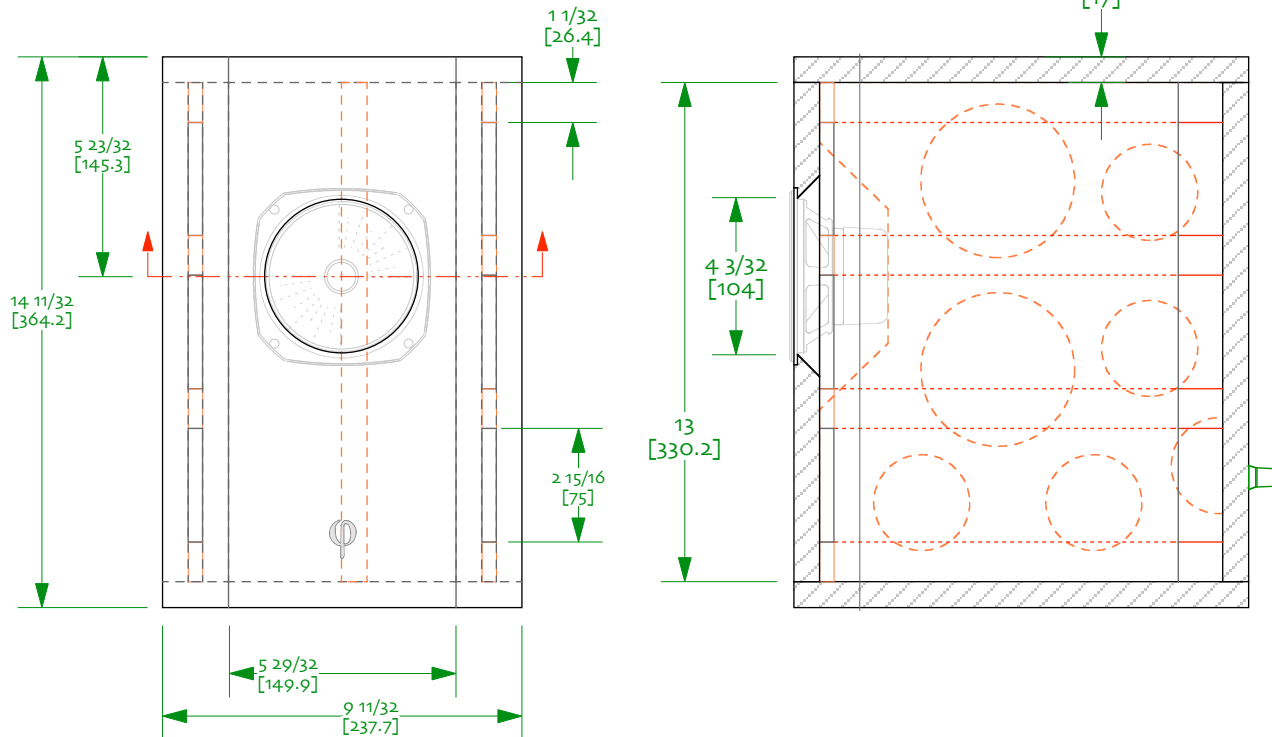

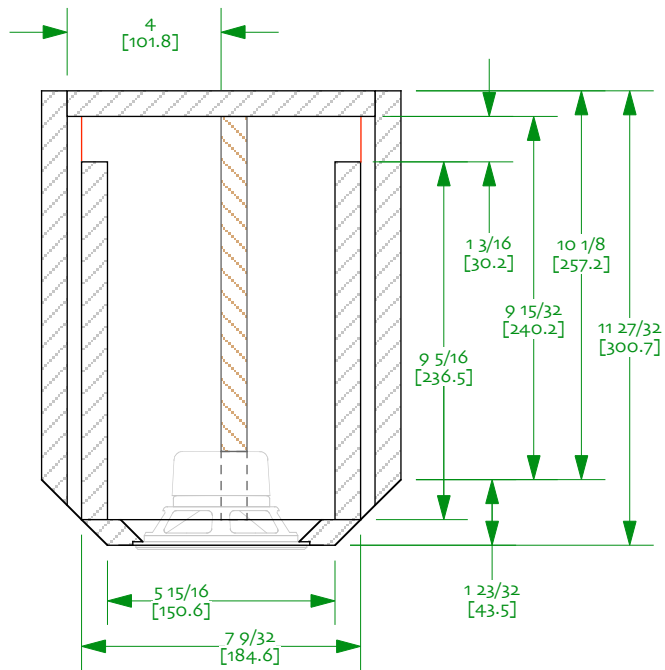

Notes:

0/ Designed for modified Fostex FE127eN, will work well with stock driver

1/ All panels 17mm

2/ Box should be made from Baltic Birch plywood or other void-free, many-ply plywood

3/ Ports are 75mm (2 15/16") long by 9.5mm (3/8") thick - 3 per side with 4 - 1 1/32" (26.4mm) solid spacers (spacers run all the way to the back of the box). MDF or solid wood spacers are preferred

4/ Brace shape is only suggestive - prime purpose is to brace speaker, it needs to be about 35-40% holes. (if you have to mount a terminal cup in the middle, you'll want to make sure the brace allows clearance)

5/ Don't forget to angle cut the back of the driver cut-out to give it breathing room

6/ All internal panels lined with ~1/2" (12mm) wool or cotton felt (preferred), 3/4" (19mm) poly-fluff batting, or 1" (25mm) fiberglass Note that it is hard to get into the box after it is sealed up



FE127eN Fonken v1.0.3b
Dimensional Drawing (17mm)

© 2007, 2008, 2009, 2010 planet_10 enterprises limited
designed & drawn by D Dlugos | 09-apr-10
for non-commercial use only

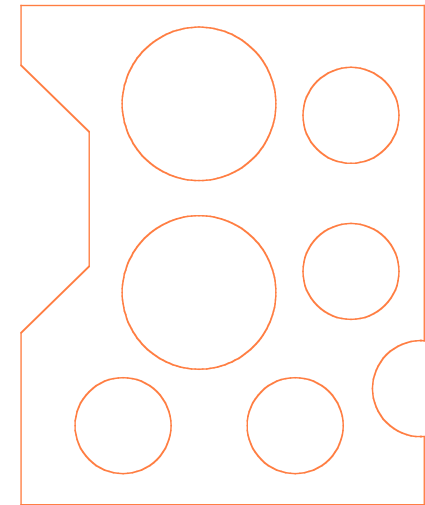
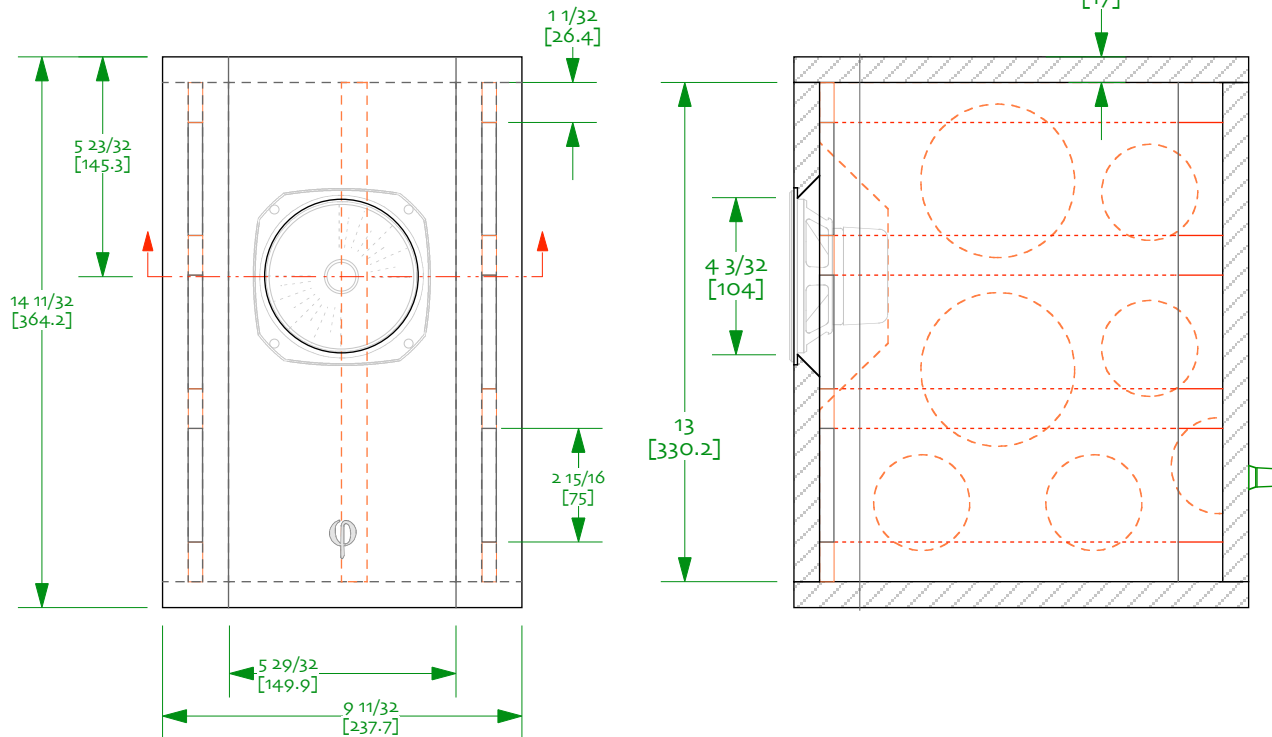

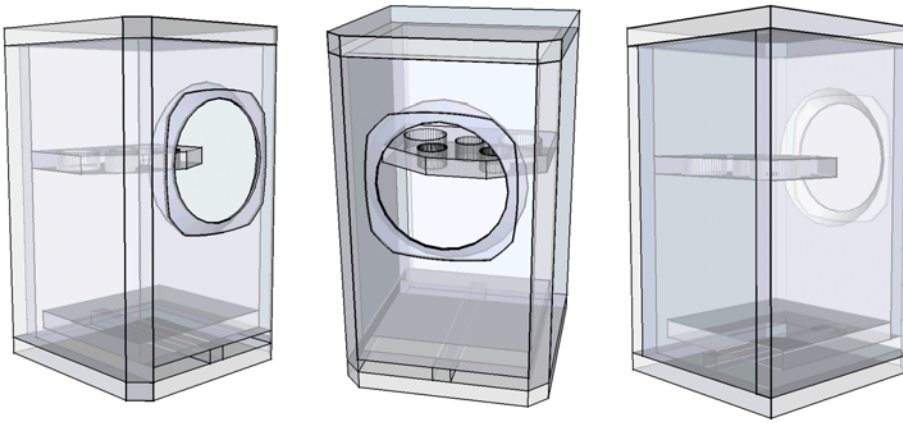

- Notes:
- 0/ drawn with 15mm (~5/8") baltic birch plywood. Adjust build dimensions for material thickness deviations
 - 1/ line with wool felt, cotton felt, or fiberglass or lightly fill with polyfluff or teased wool
 - 2/ open up the back of the driver cutout – preferably 45°
 - 3/ thicker front baffle or optional cleat can be added on front corners if you'd like to increase size of the bevel (requires cutting or routing after box construction)
 - 4/ if front baffle is increased in thickness, then the length of the port-slot top shelf needs to be decreased in length by half the increase in the baffle thickness

optional cleat added so bevel size on front can be increased... make sure it is cut away around the driver

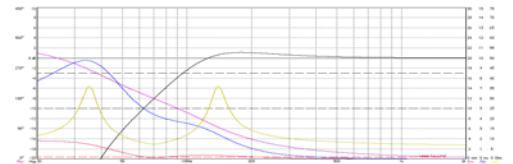
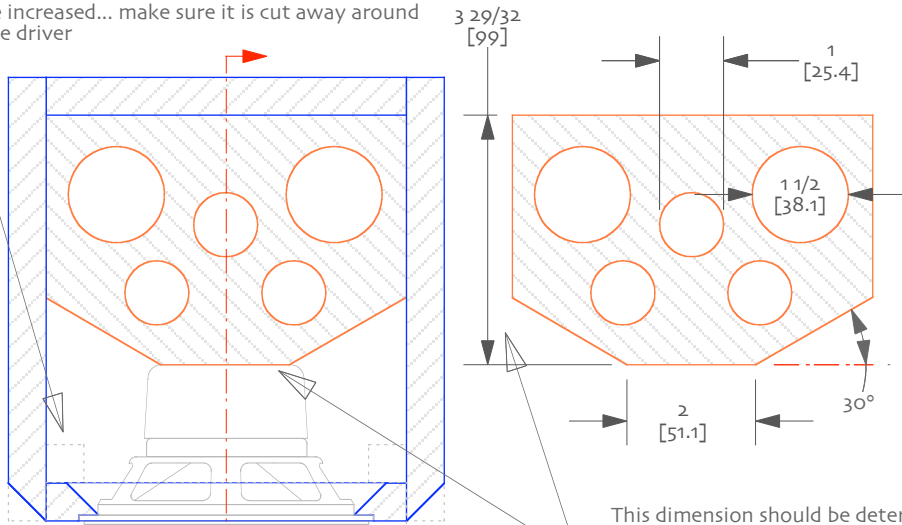

Simulation – this does not take into account the high aspect ratio port. Actual FR (black) will have less bump and slower roll-off, group delay (blue) will be less, excursion (red) will be more controlled, impedance (yellow) will have asymmetrical humps.

This dimension should be determined in the field... the brace should be tight against the magnet of the driver, but not so much that it stresses the basket... small paper shims can be used if necessary.

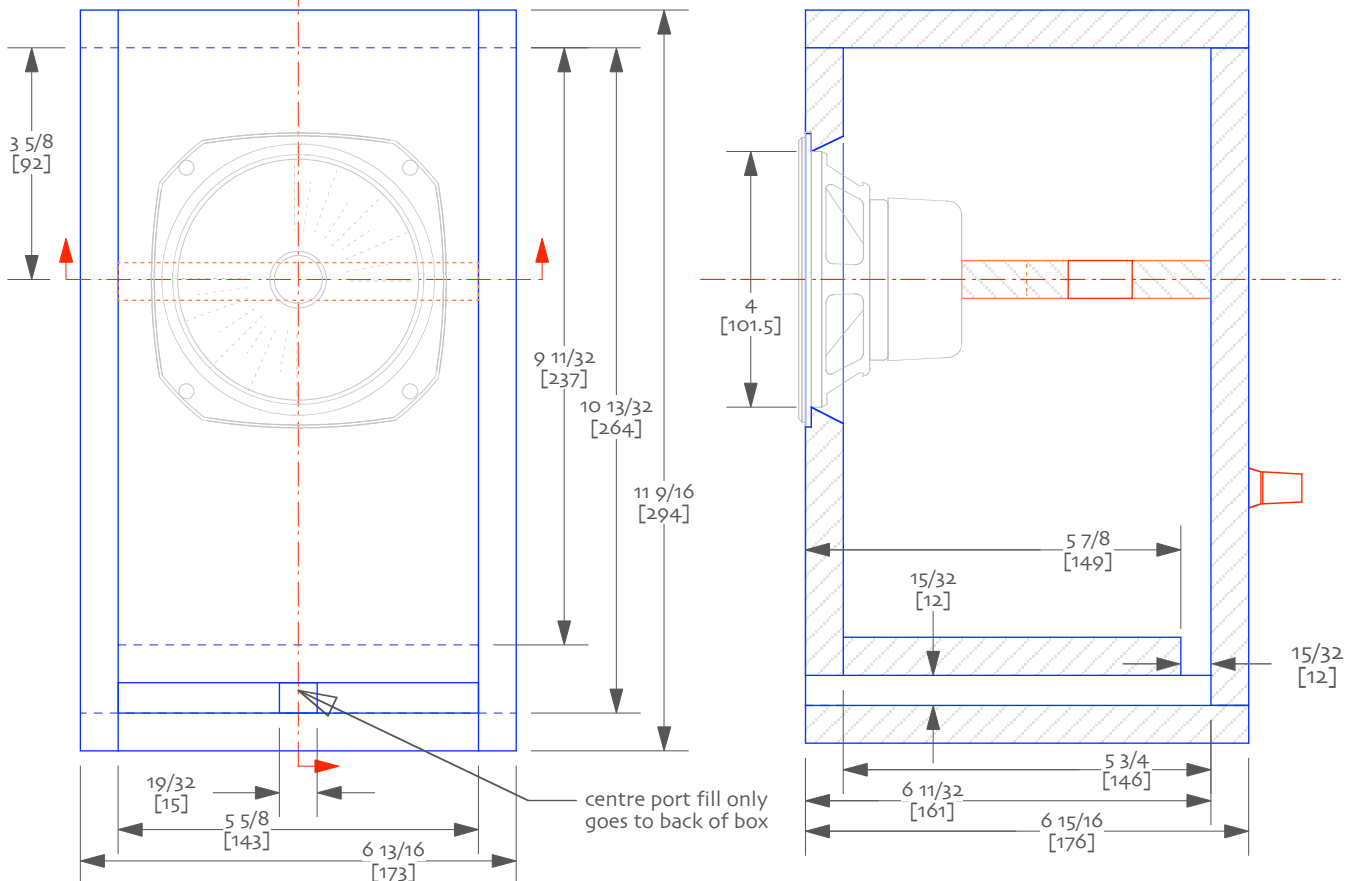



Classic Fonken GR /FE127e ov6

© 2007 planet_10 enterprises limited
 01 - april -2007
 designed & drawn by dld
 free for non-commercial use only

Notes:

0/ A classic Golden Ratio based derivative of the Fonken designed for modified Fostex FE127e, will work well with stock driver

1/ to be built as mirror imaged pairs

2/ All panels 5/8" (15mm)

3/ Ports are 3/4" (19mm) high and the width is defined by adding a 5/8" (15mm) solid spacers

4/ brace shape is only suggestive -- prime purpose is to brace driver, it needs to be about 35-40% holes. (ie if you have to mount a terminal cup in the middle, you'll want to make sure the brace allows clearance)

5/ Don't forget to angle cut the back of the driver cut-out to give it breathing room

6/ All internal panels lined with ~1/2" (12mm) wool felt (preferred), 3/4" (19mm) poly-fluff batting, or 1" (25mm) fiberglass Note that it is hard to get into the box after it is sealed up

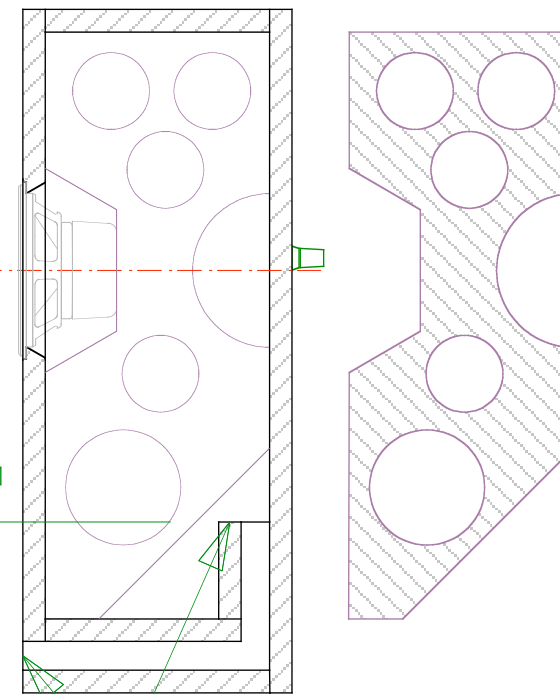
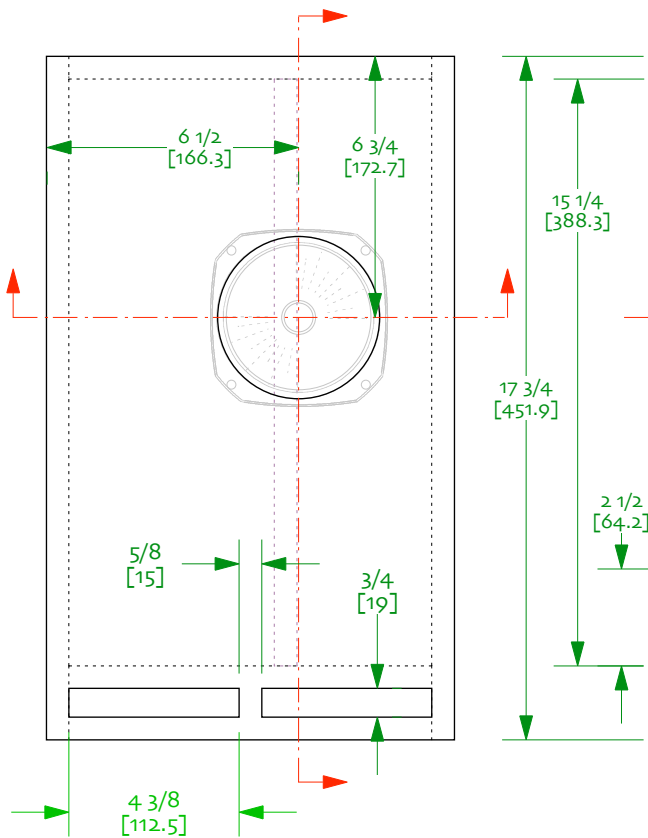
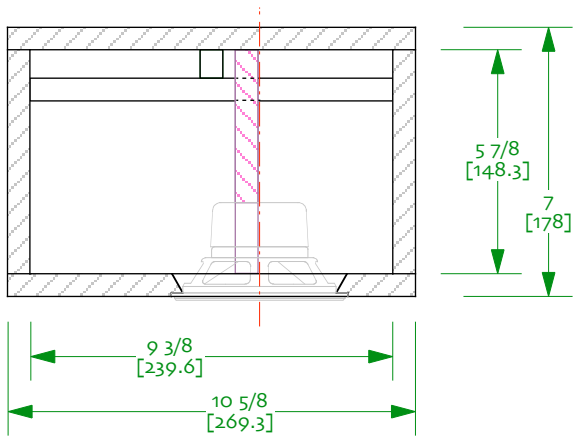

port exit and entrance need roundover, an additional piece may be required on the bottom

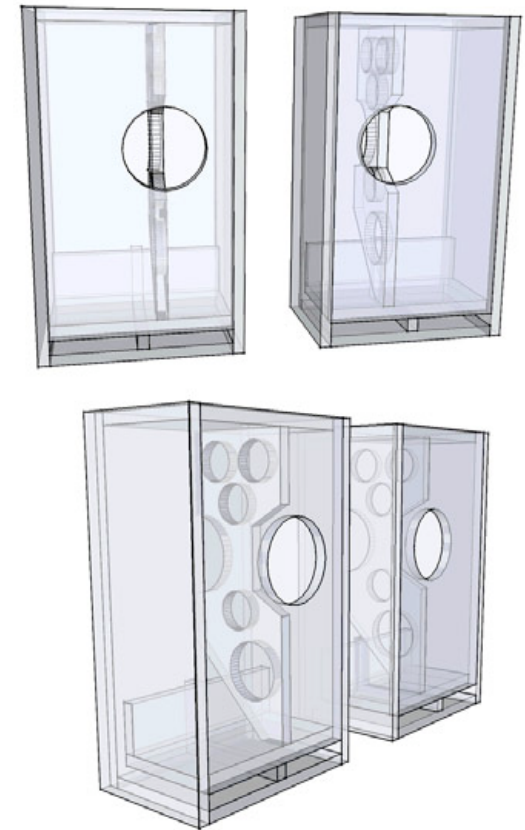

Notes:

o/ 15mm material

1/ aspect ratio as drawn, $630 / 385 = 1.636$



wallFonken Take 3 FE127e

© 2009 planet_10 enterprises limited
20- january -2009 designed & drawn by dld
free for non-commercial use only

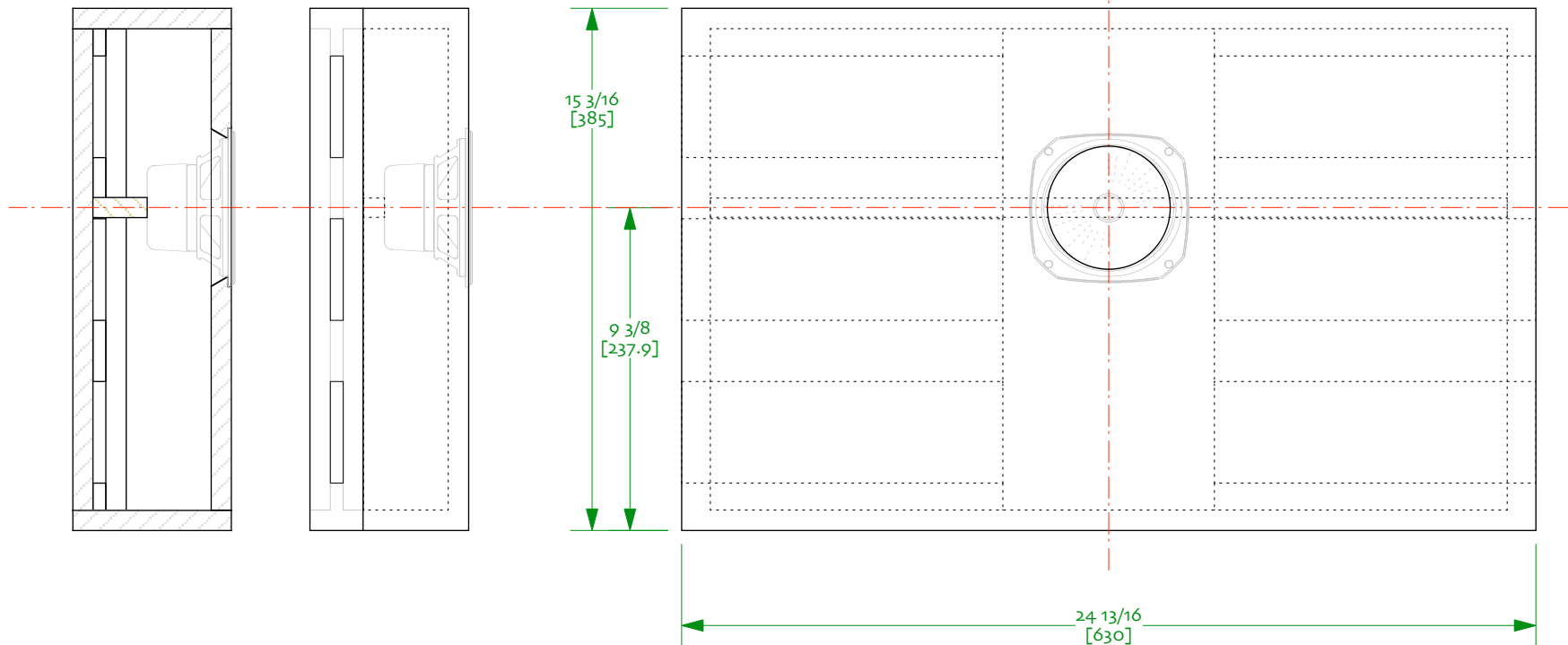
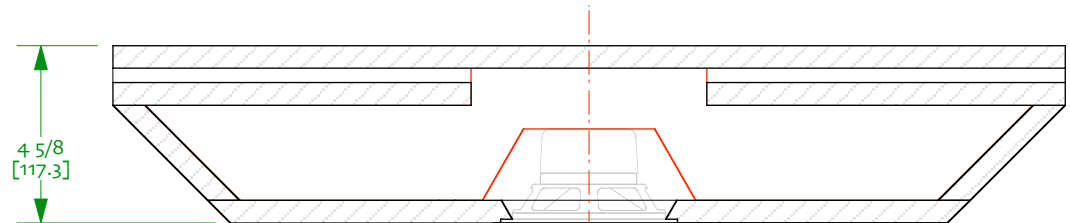

Notes:

0/ drawn with 15mm material

1/ a Fonken has its walls lined with 1/2" cotton or wool felt. Due to the tall skinny nature of this impementation, some quarter-wave characteristics a taken on and some very loose polyfill or wool fill ma be required to reduce some lower midrange ripple (0.1-0.23 lb / 45-106 g). The chart (modeled in MJK) with no damping (red) and with 45 g of polyfluff (green), but no lining on the walls -- it shows the potential for ripple.

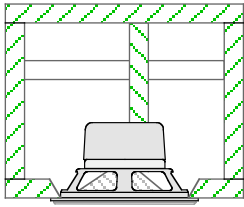

2/ the holey internal brace can be extended all the way down for inceased panel stiffness.

3/ driver can be moved off the centre-line in which case mirror images pairs would be made.



FE127e Fonken-tuned floorstander
Mark II

© 2007 planet_10 enterprises limited
02-april -2007
designed & drawn by dld
free for non-commercial use only

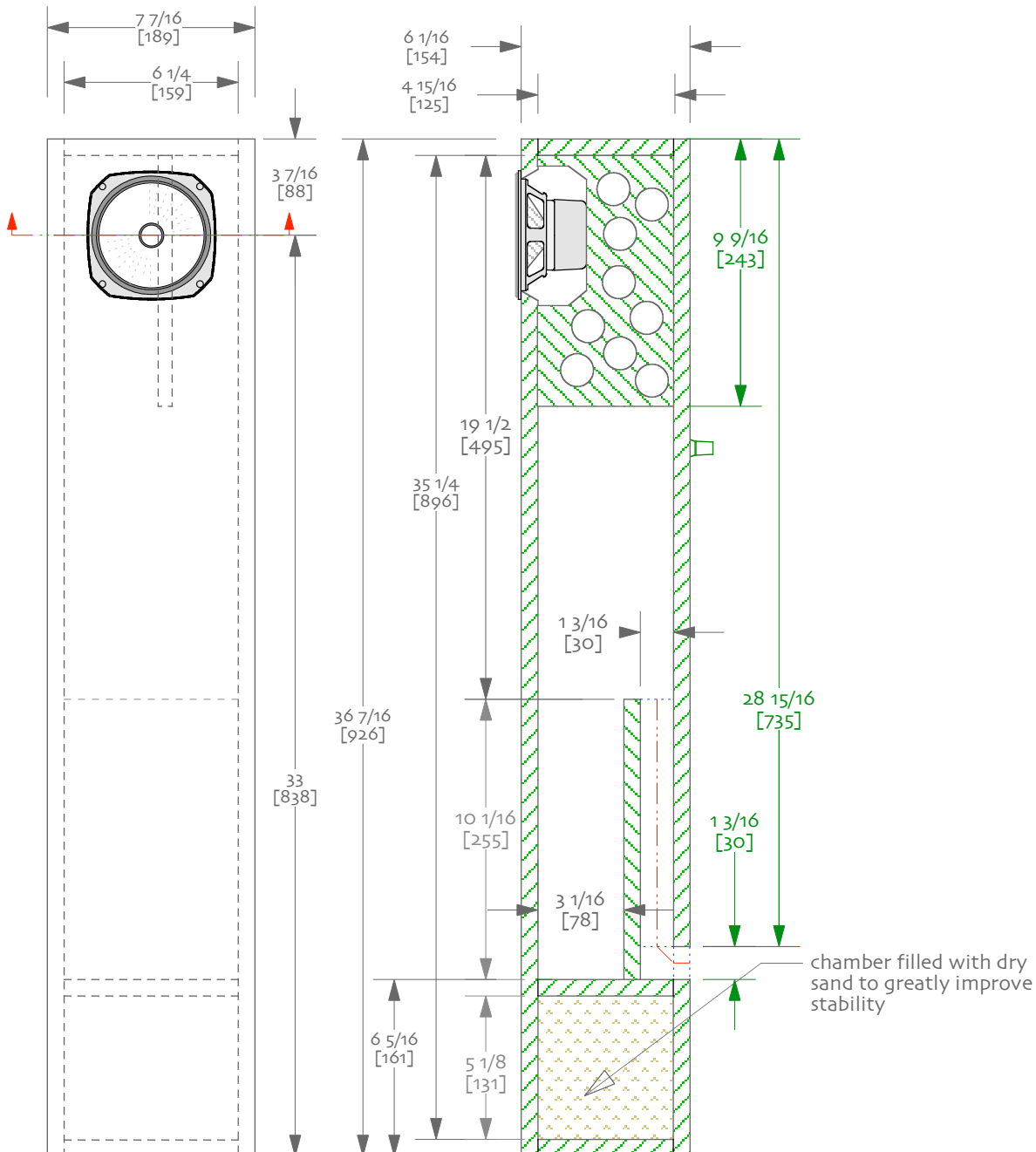

Notes:

o/ drawn with 15mm material

1/ a Fonken has its walls lined with 1/2" cotton or wool felt. Due to the tall skinny nature of this impementation, some quarter-wave characteristics are taken on and some very loose polyfill or wool fill may be required to reduce some lower midrange ripple (0.1-0.23 lb / 45-106 g). The chart (modeled in MJK) is with no damping (red) and with 45 g of polyfluff (green), but no lining on the walls -- it shows the potential for ripple.

2/ the holey internal brace can be extended all the way down for increased panel stiffness.

3/ driver can be moved off the centre-line in which case mirror images pairs would be made.



FE127e Fonken-tuned floorstander

Mark 2,1

© 2008 planet_10 enterprises limited

13-march -2008

designed & drawn by dld

free for non-commercial use only

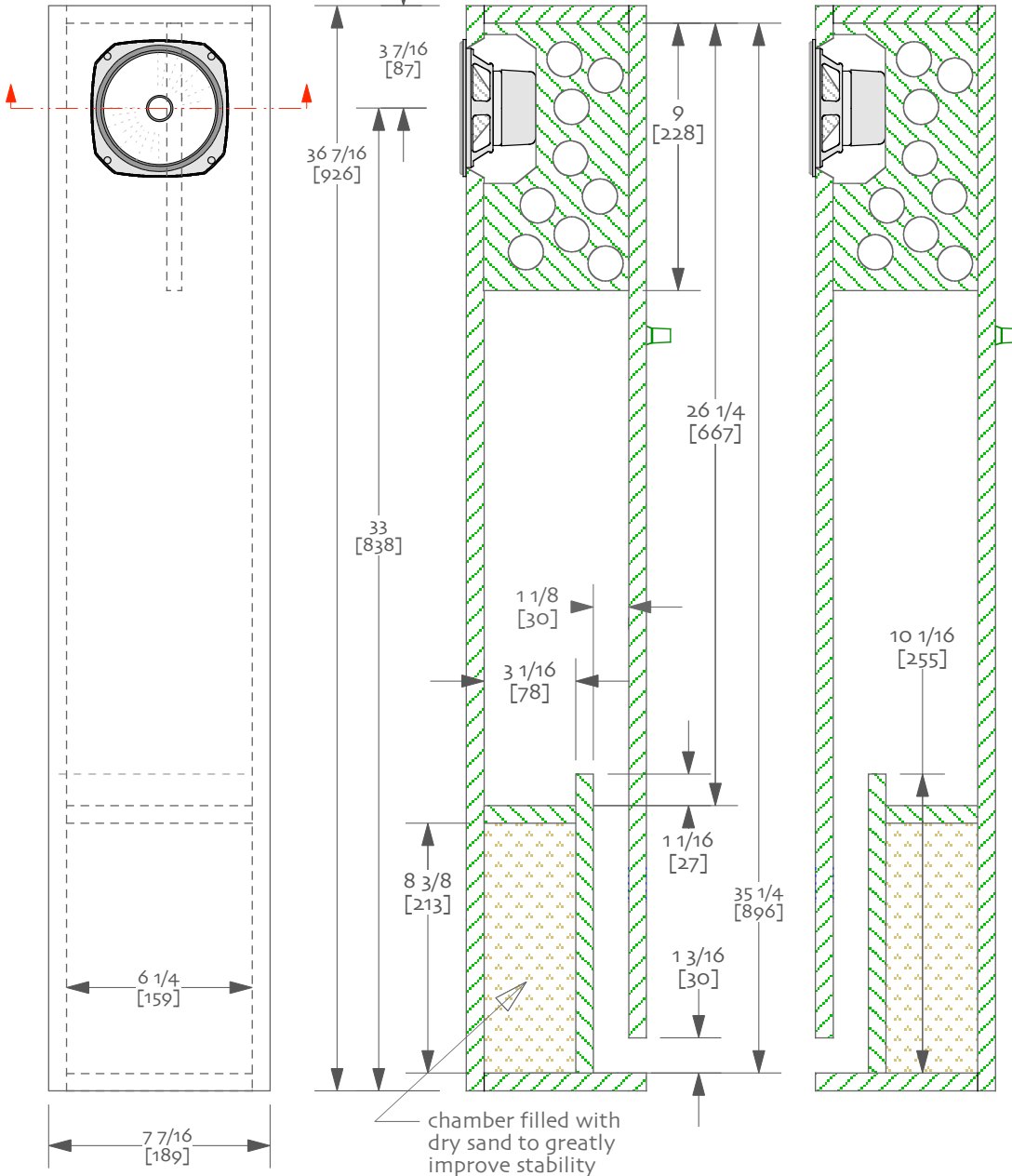
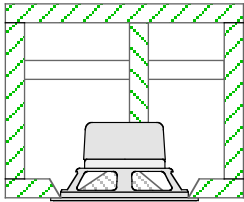
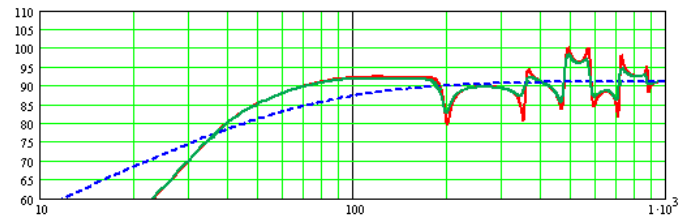

FE127e Fonken-tuned floorstander

© 2006 planet_10 enterprises limited
 01-july -2006
 designed & drawn by dld
 free for non-commercial use only

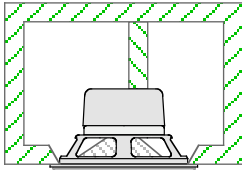

Notes:

o/ drawn with 15mm material

1/ a Fonken has its walls lined with 1/2" cotton or wool felt. Due to the tall skinny nature of this impementation, some quarter-wave characteristics are taken on and some very loose polyfill or wool fill may be required to reduce some lower midrange ripple (0.1-0.23 lb / 45-106 g). The chart (modeled in MJK) is with no damping (red) and with 45 g of polyfluff (green), but no lining on the walls -- it shows the potential for ripple.

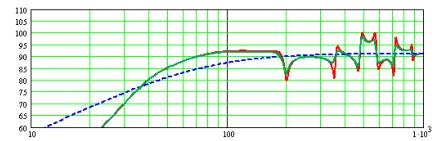

2/ the holey internal brace can be extended all the way down for increased panel stiffness.

3/ driver can be moved off the centre-line in which case mirror images pairs would be made.

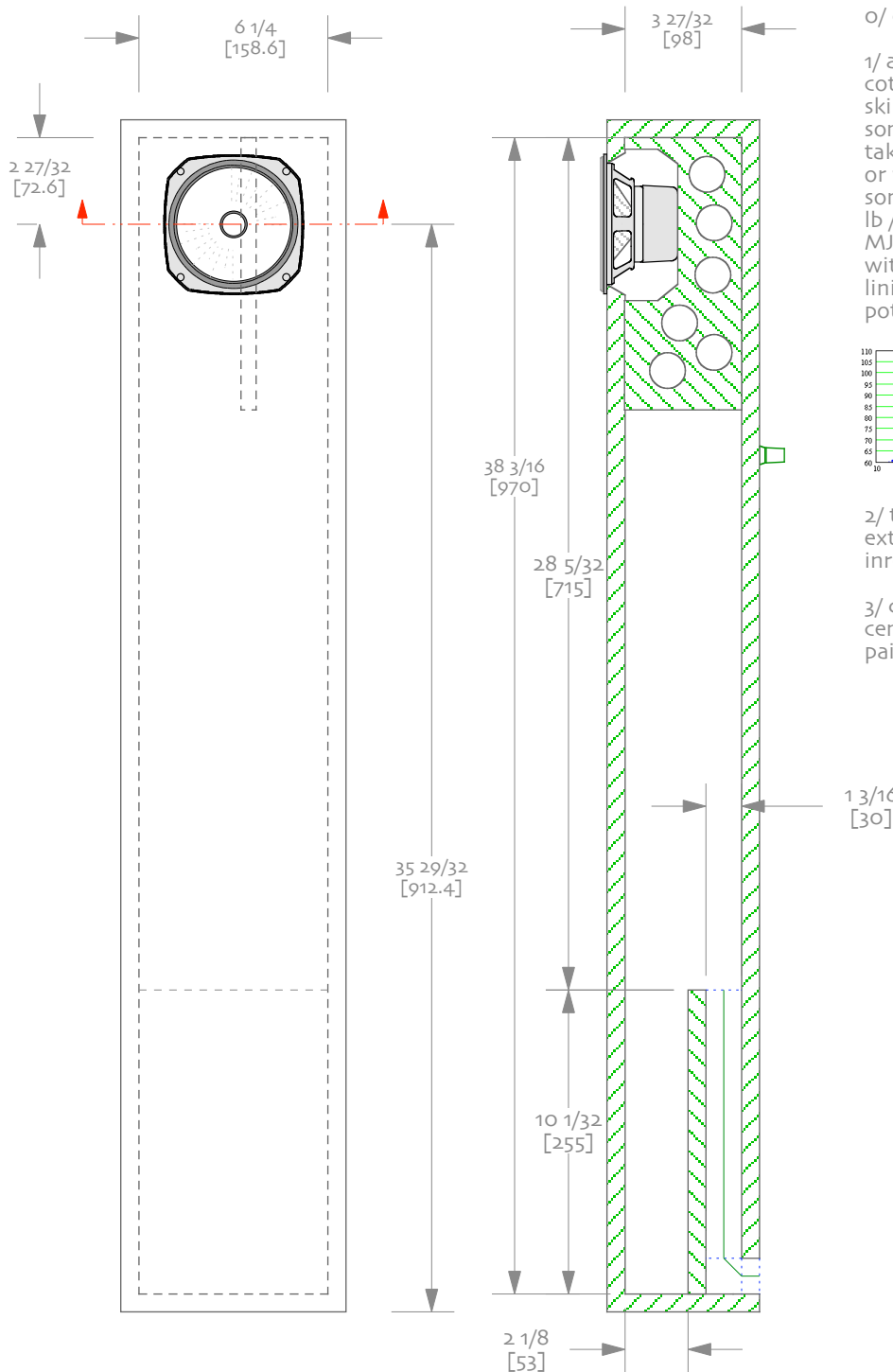



FE127eN Fonken v1.0.3b
Damping 1

© 2009-2014 planet_10 enterprises limited
designed & drawn by D Dlugos | 25-july-14
for non-commercial use only

Notes:

- 1/ ~12mm *(1/2") cotton or wool felt
- 2/ measure actual dimensions in situ before cuttin
- 3/ install before the last panel goes on
- 4/ white glue ot hot glue can be used to secure felt (only spots needed)

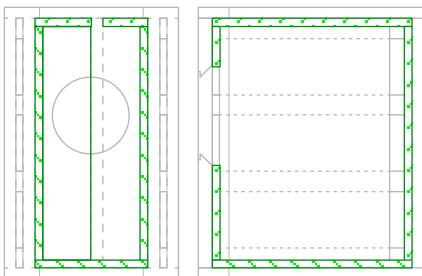
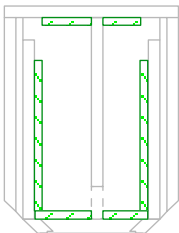
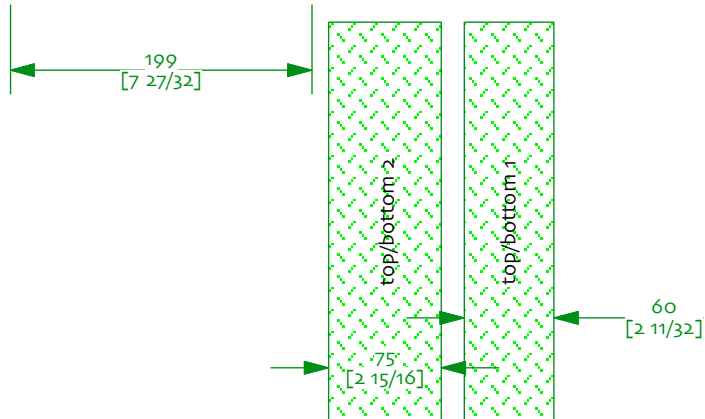
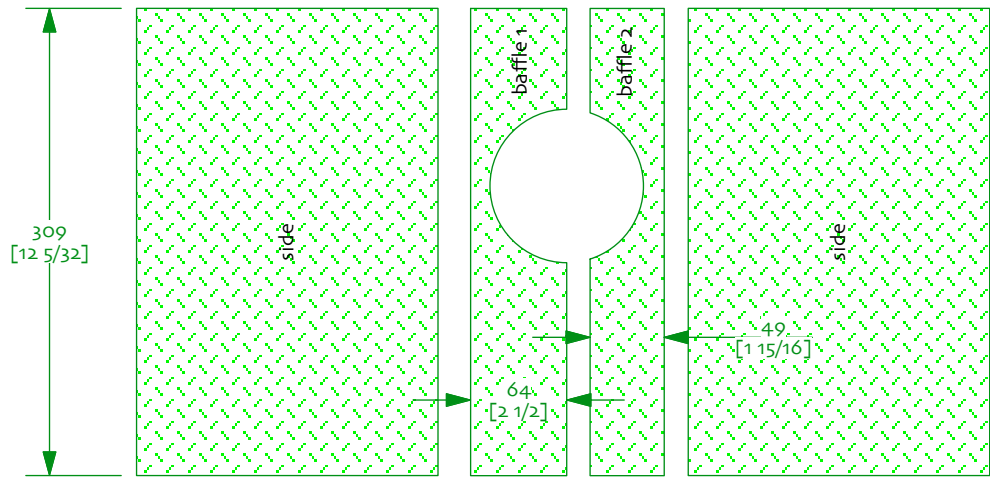
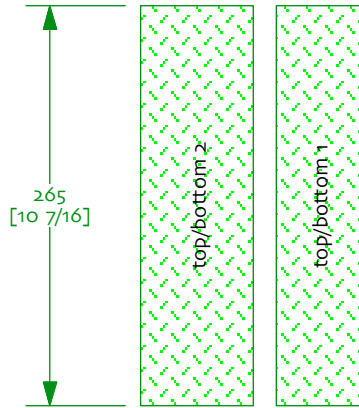
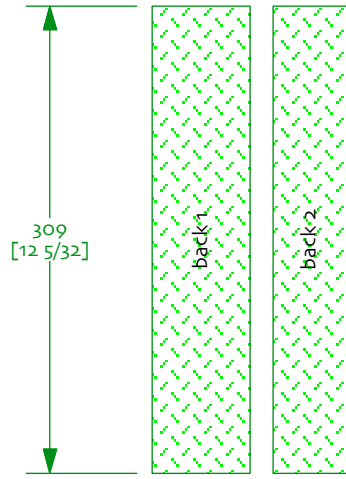

FE127eN Fonken v1.0.3b
Damping 2 | Cut Plan

© 2009-2014 planet_10 enterprises limited
designed & drawn by D Dlugos | 25-july-14
for non-commercial use only

